

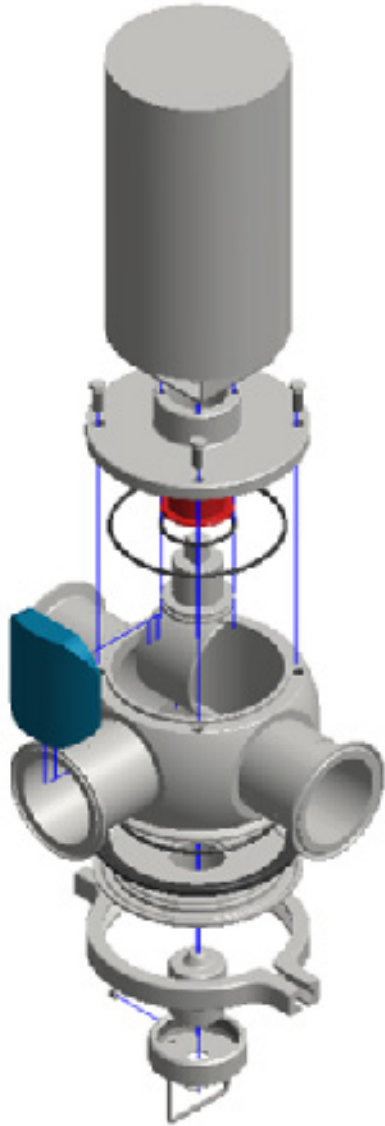

EASY-OPEN Bogenventil für die Fleischindustrie
EASY-OPEN Arc Valve for the meat industry

EASY-OPEN Bogenventil für die Fleischindustrie

EASY-OPEN Arc Valve for the meat industry



LIAG® EASY-OPEN Bogenventile werden vorwiegend in Metalldetektoren und Anlagen der Fleischwarenindustrie ohne CIP-Reinigung eingesetzt. Leichte und schnelle Zugänglichkeit, sowie sehr gute Reinigbarkeit sind hier Grundvoraussetzung.

LIAG® EASY-OPEN arc valves are specially designed as reliable component of inline metal detectors and process lines in the meat industry without CIP Cleaning. This valve performs easy and quick opening with excellent cleanability.

Merkmale

- Hygienisches Design - keine Toträume
- Völlig freier Durchgang - kein Druckverlust
- Minimum an Bau- und Verschleißteilen
- EASY-OPEN Design zum schnellen Öffnen im eingebauten Zustand

Features

- Hygienic design - no dead pockets
- Totally clear passage - no pressure loss
- Minimum number of components and wearing parts
- EASY OPEN design for fast opening even when built in

**Individualisierbare
Ventil Anschlüsse**
Customized valve
connections

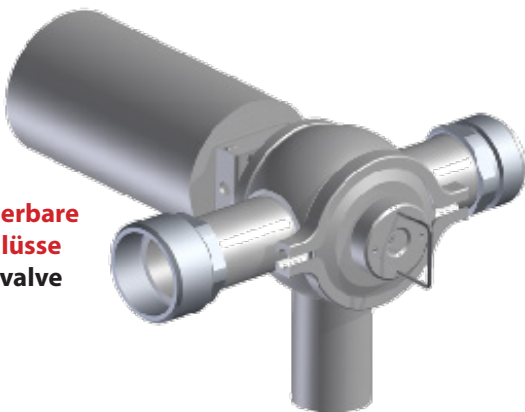

**Schnell schaltender
Edelstahlantrieb**
Fast switching stainless
steel actuators

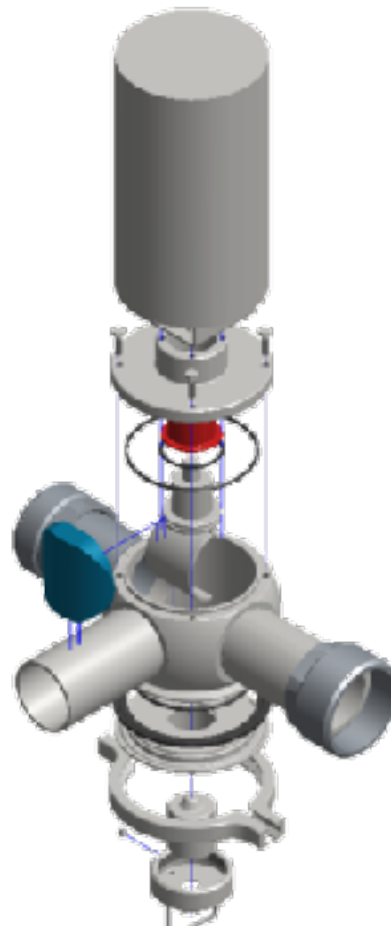

Technische Daten

Technical data

Nennweiten DIN DN50 - DN80 / SMS DN51 - DN76 / Zoll 2" - 3"	Nominal sizes DIN DN50 - DN80 / SMS DN51 - DN76 / Inch 2" - 3"
Werkstoffe Produktberührende Edelstahlteile: AISI 316L (1.4404 / 1.4435) Andere Edelstahlteile: AISI 304 (1.4301) O-Ring Dichtungen: EPDM, FKM (Viton®), FEP, andere Qualitäten auf Anfrage Schließer: PTFE Für Fleischbrät mit eventuellen Rückständen von abrasiven Knochensplittern wird der Einsatz des Schließersmaterials PTFE+15% Peek empfohlen.	Materials Inox parts in contact with product: AISI 316L (1.4404 / 1.4435) Other inox parts: AISI 304 (1.4301) O-ring seals: EPDM, FKM (Viton®), FEP, other grades upon request Shutter: PTFE For meat paste with eventual residues of abrasive particle of e.g. bones we recommend to use the shutter material PTFE+15% Peek.
Oberflächen Produktberührend: Ra ≤ 0,8 µm (Ra 32 µin)	Surfaces In contact with product: Ra ≤ 0,8 µm (Ra ≤ 32 µin)
Temperatur Betriebstemperatur: 110°C (230°F) Kurzzeitig: 140°C (284°F) - Optional bis 200°C (392°F)	Temperature Operating temperature: 110°C (230°F) Short-term: 140°C (284°F) - optionally up to 200°C (392°F)
Betriebsdruck Druck hinter Federbogen: 10 bar (145 psi) - Optional bis 20 bar (290,1 psi) Druck gegen Federbogen: 3 bar (43,5 psi)	Operating pressure Pressure behind arc: 10 bar (145 psi) - optionally up to 20 bar (290,1 psi) Pressure against arc: 3 bar (43,5 psi)
Ventilanschlussarten Schweißende: DIN, SMS, Zoll Gewinde: DIN 11851, SMS 1145 Clamp: Tri-Clamp Andere: Auf Anfrage	Valve connection Welded ends: DIN, SMS, Zoll Male ends: DIN 11851, SMS 1145 Clamp connection: Tri-Clamp Others: upon request
Weitere Optionen <ul style="list-style-type: none">• Schließerwerkstoff; alternativ: Tecapeek®, PTFE+15% Peek• Kombination verschiedener Anschlussarten• Unterschiedliche Antriebsfabrikate nach Namur NE14 und DIN EN ISO5211 liefer- und adaptierbar	Further options <ul style="list-style-type: none">• Shutter material; alternatively: Tecapeek®, PTFE+15% Peek• Combination of different types of connection• Delivery and adaptation to actuators of different manufacture per Namur NE14 and DIN EN ISO5211

LIAG® LÄUFER International AG - Am Wasserstall 12 - 88682 Salem / Germany

T +49 7553 59089 0 - support@liag-valve.com - www.liag-valve.com

